

Static and dynamic testing of bridges and highways using long-gage fiber Bragg grating based strain sensors

Whitten L. Schulz^{*a}, Joel P. Conte^b, Eric Udd^a, John M. Seim^a

^aBlue Road Research, 2555 NE 205th Ave., Fairview, OR 97024.

^bDept. of Civil and Env. Engrg., Univ. of California, Los Angeles

ABSTRACT

Fiber optic Bragg gratings packaged in long gage configurations are being used to measure static and dynamic strain in structures and structural models to monitor structural health and predict damage incurred from a seismic event. These long gage sensors are being used to experimentally verify analytical models of post-earthquake evaluation based on system identification analysis. This fiber optic deformation measurement system could play a significant role in monitoring/recording with a higher level of completeness the actual seismic response of structures and in non-destructive seismic damage assessment techniques based on dynamic signature analysis. This new sensor technology will enable field measurements of the response of real structures to real earthquakes with the same or higher level of detail/resolution as currently in structural testing under controlled laboratory conditions.

Keywords: Macroscopic strain, dynamic strain measurements, optical

1. INTRODUCTION

Determination of the actual nonlinear inelastic response mechanisms developed by civil structures such as buildings and bridges during strong earthquakes and post-earthquake damage assessment of these structures represent very difficult challenges for earthquake structural engineers. Presently, there is an unbalance between the analytical capabilities for predicting various nonlinear structural responses and damage parameters and the incompleteness (lack of richness) of the information on the actual seismic response of structures measured in the laboratory and, more importantly, in the field. Furthermore, this unbalance impedes the full deployment of the new and very appealing philosophy of performance-based earthquake engineering.

The research being performed aims at filling the gap defined above through studying the feasibility, through physical experimentation at small scale, of using long gage fiber optic Bragg grating sensors for monitoring directly the “macroscopic” internal deformation response of structures to strong ground motions and for non-destructive post-earthquake evaluation of structures. These fiber optic sensors can be either embedded inside a reinforced concrete or composite structure or bonded to the surface of a steel structure and monitored real-time at speeds in excess of 1kHz.

1.1. Fiber Bragg Grating Sensor

The core sensor technology for this project is the fiber Bragg grating. A Bragg grating consists of a series of perturbations in the index of refraction along the length of a fiber (Udd, 1991). This grating reflects a spectral peak based on the grating spacing, thus changes in the length of the fiber due to tension or compression will

* Correspondence: Email: whitten@teleport.com; WWW: <http://www.bluerr.com>; Telephone: 503 667 7772 x102; Fax: 503 667 7880

change the grating spacing and the wavelength of light that is reflected back. Quantitative strain measurements can be made by measuring the center wavelength of the reflected spectral peak. Fig. (1) shows a Bragg grating and the effects of a broadband light source impinging on the grating.

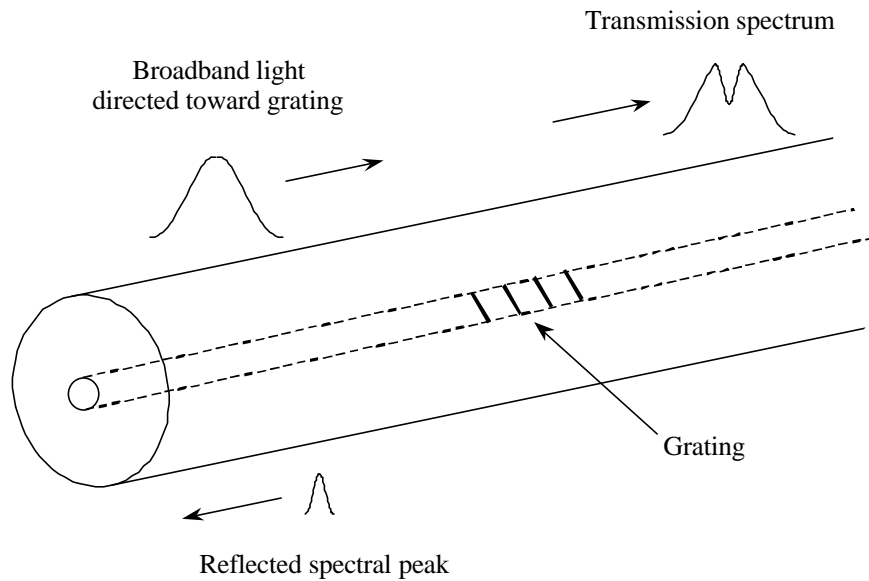

Fig. 1 Transmission and reflection spectra from fiber Bragg grating

In its basic form, a typical Bragg grating has a gage of approximately 5mm. For most civil structure applications this gage is too short, so a method of effectively increasing the gage was developed.

1.2. Long Gage Grating Sensors

In order to increase the gage of the Bragg grating to provide a more macroscopic strain value useful in civil structure applications, the grating is packaged in a tube with the tie points defining the effective gage. Fig. (2) shows a long gage sensor with optional brackets for surface mounting.

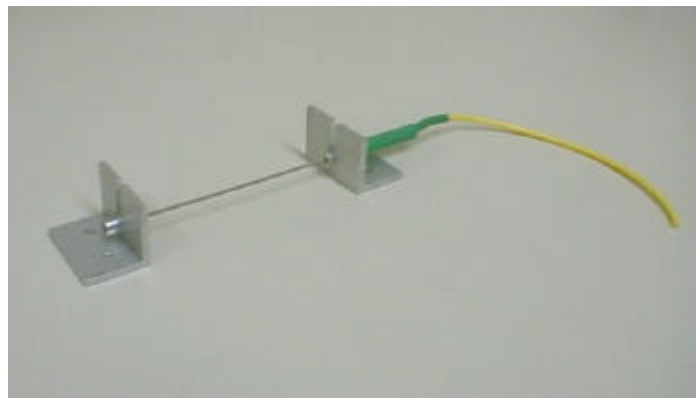

Fig. 2 Long gage grating sensor shown with optional brackets for surface mounting capability

This packaging provides a gage range from 2.5 to 100 cm. The maximum diameter of the grating package is less than 8mm, making it non-obtrusive and ideal for embedding into composites, placing into grooves in concrete, etc.

1.3. Dynamic Strain Measurement

The analytical models in this project require dynamic strain measurements for experimental verification. A high-speed fiber grating demodulation system has been developed that can measure strain from DC levels up to 10Mhz (Seim, 1998). For this project, the system has been optimized for 1 kHz, which provides sufficient oversampling. This demodulation system consists of a grating filter that converts the spectral information from the grating sensor into an amplitude based signal measurable by photo detectors. Fig. (3) shows this system where light is directed into the sensor through the first beam splitter, reflected in the grating and directed into the second beam splitter where it is divided into the filtered and reference legs and then into the high speed detector. The reference leg compensates for amplitude losses in the system.

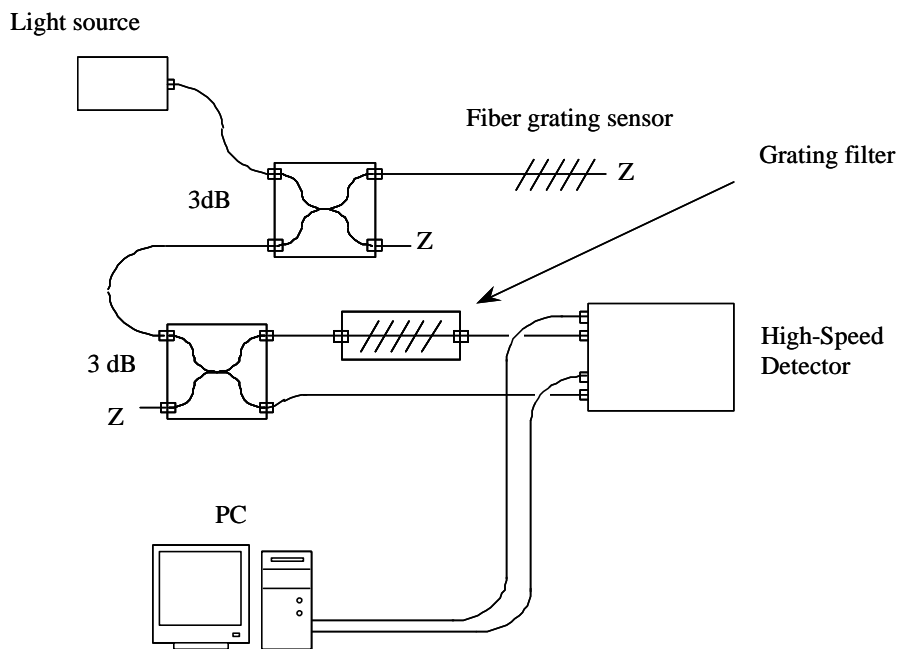

Fig. 3 High-speed demodulation system

This high-speed system can also be expanded to support more than one grating sensor as represented in Fig. (4).

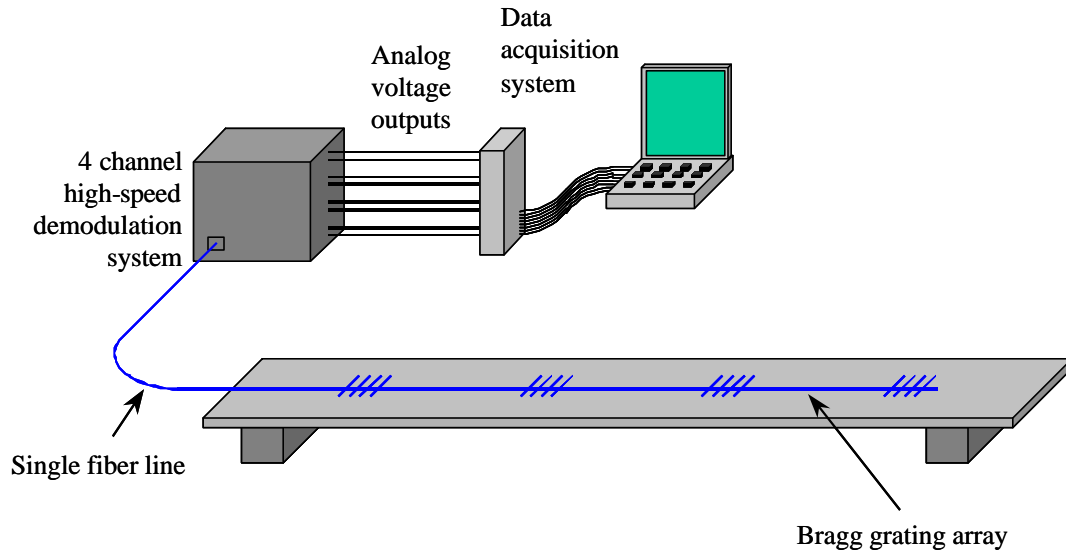

Fig. 4 High-speed measurement of a series of fiber gratings along a single fiber line

2. CIVIL STRUCUTRE EXAMPLES

Feasibility is an important aspect of introducing new technology and the sensors and system described above have been used on an actual structure with good success. One of the examples below has been providing long-term survivability and sensor performance data while a new project has the potential of monitoring a bridge during demodulation.

2.1. Horsetail Falls Bridge

Twenty-six sensors have been successfully monitoring the Horsetail Falls Bridge in Oregon for two years (Seim, 1999). The bridge, shown in Fig. (5), was built in 1914 and in 1998 underwent a strengthening procedure where composite wrap was placed over the concrete beams.



Fig. 5 Horsetail Falls Bridge before being strengthened by composite wrap and instrumented with 26 long gage fiber grating strain sensors

To verify that the composite wrap was adding strength to the bridge, long gage fiber grating strain sensors were placed in grooves cut into the concrete and in the wrap itself. Fig. (6) shows the sensors being embedded into the concrete and composite wrap.



Fig. 6 Sensors being placed into grooves in the concrete (left) and embedded into the composite wrap (right)

Using the high-speed demodulation system, several dynamic tests were performed on the bridge. Fig. 7 shows results from one of the tests focusing on one sensor as traffic was monitored.

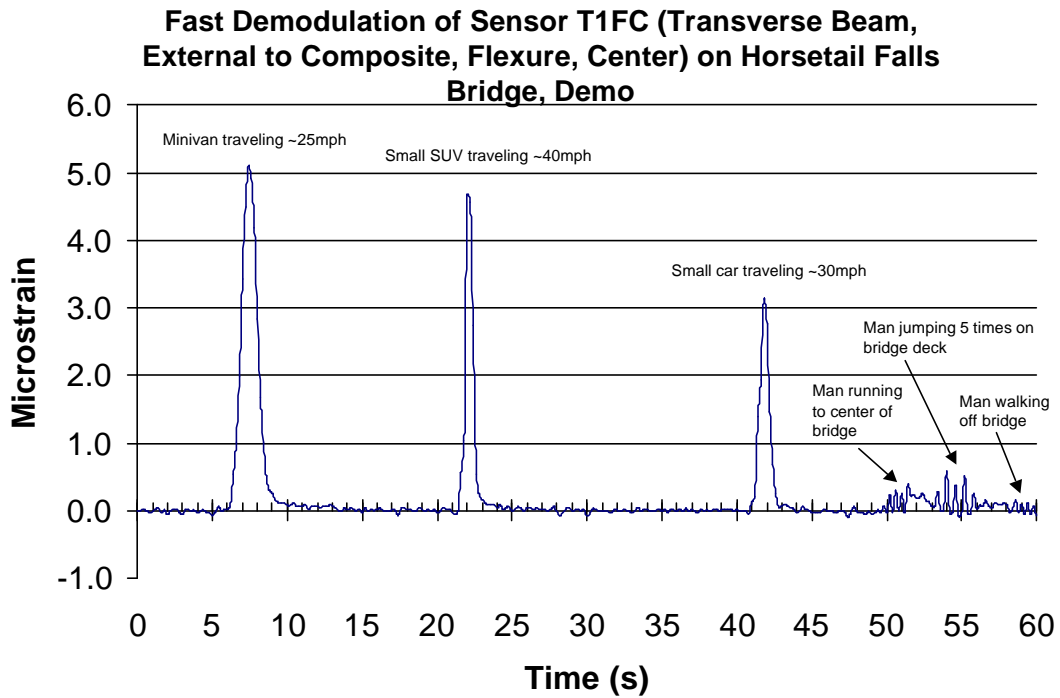

Fig. 7 Dynamic data from a sensor installed on the Horsetail Falls Bridge

The high-speed demodulation system has a high sensitivity as demonstrated by the resolution of less than 0.1 microstrain in the above data.

2.2. Sylvan Bridge

In mid July, 2000 14 long gage sensors were installed on another Oregon bridge shown in Fig. (8). This bridge also received composite wraps, but in strips as opposed to sheets. This could be an important part of this seismic damage assessment project as the bridge is tentatively scheduled to be destroyed in 3-5 years. This will allow for severe, damaging forces to be monitored with the sensors and compared to analytical models.



Fig. 8 Sylvan Bridge in Oregon scheduled for instrumentation mid July 2000

3. EXPERIMENTAL VERIFICATION OF THE ANALYTICAL SEISMIC DAMAGE MODEL

While the applications listed above provide excellent structural health and feasibility information, it is still necessary to use models to verify the analytical seismic damage model being developed. These experiments will be conducted in two main stages, free and forced vibration. Damage will also be induced during this dynamic testing and compared to predicted damage locations.

3.1 Free Vibration

The first set of experiments will employ an aluminum beam with various combinations of boundary conditions and mass distributions. The beam will be approximately 100 cm long and have three sensors with gages of 15 cm. Fig. 9 shows a representation of the beam and the various configurations. Several long gage sensors will be placed at key locations on the beam to measure macro strain during free vibration. These strain values will then be compared to results from the analytical model.

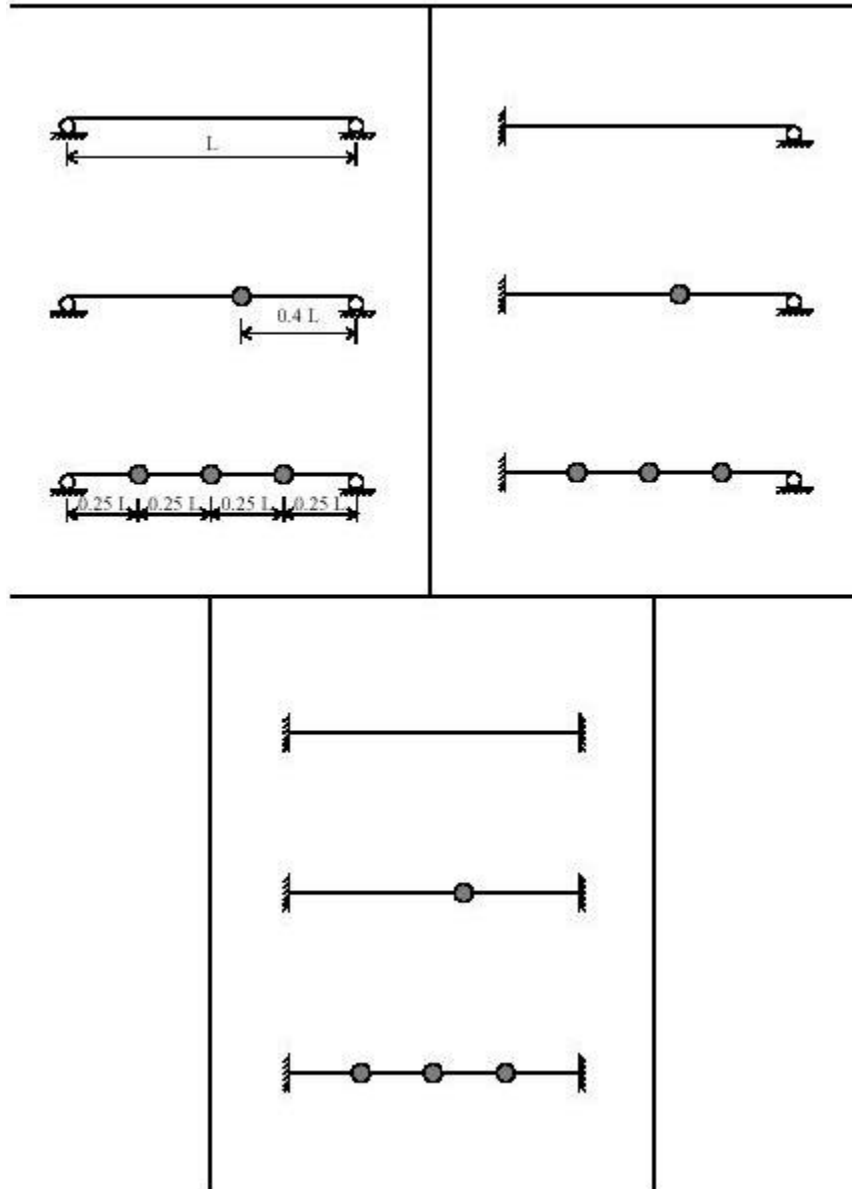

Fig. 9 Different mass distributions and boundary conditions for test beam in free vibration

This rigorous set of free vibration experiments will better verify the analytical model and the long gage sensors.

3.2 Forced Vibration

The second main set of experiments will involve forced vibrations with more complex models better representing real structures. Fig. 10 shows the forced vibration setup with a shaker table and examples of potential models.

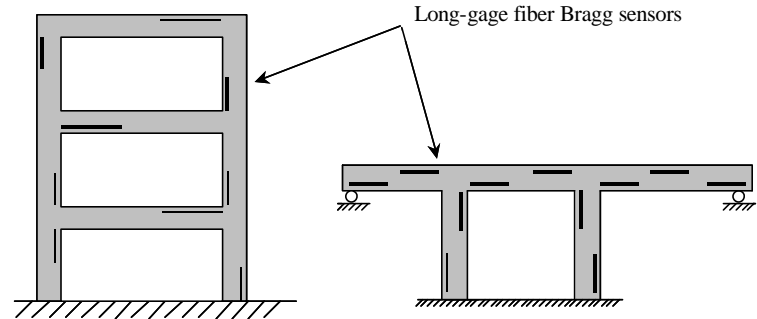

Fig. 10 Shaker table setup (left) and structural models (right) of forced vibration tests

3.3. Induced Damage

The analytical model has the capability to predict where damage has occurred based on dynamic signature analysis. During dynamic testing, damage will be simulated by reducing the cross sectional area of the models at known points to see if the analytical model gives the same damage location.

4. SUMMARY

Long gage fiber optic Bragg grating sensors are being used to monitor the structural health of structures and to provide experimental verification of a seismic damage identification model. The long gage is to provide a macroscopic strain value more useful in structural monitoring. These sensors have the capability of measuring dynamic strain up to several kHz, which is an important aspect of seismic monitoring and testing.

ACKNOWLEDGEMENTS

The work for this project has been partially funded by The National Science Foundation (Grant # DMI-9961268) and The United States Navy (Contract # N68335-99-C-0242.)

REFERENCES

1. Seim, J., E. Udd, W. Schulz, and H.M. Laylor (1999). "Composite Strengthening and Instrumentation of the Horsetail Falls Bridge with Long Gauge Length Fiber Bragg Grating Strain Sensors", *SPIE Proceedings*, Vol. 3746, p. 196, 1999.
2. Seim, J.M., W.L. Schulz, E. Udd, K. Corona-Bittick, J. Dorr, and K.T. Slattery (1998). "Low-Cost High-Speed Fiber Optic Grating Demodulation System for Monitoring Composite Structures", *SPIE Proceedings*, Vol. 3326, p. 390, 1998.
3. Udd, E. (1991). *Fiber Optic Smart Structures in Fiber Optic Sensors: An Introduction for Engineers and Scientists*, Edited by E. Udd, Wiley, 1991.